

Date

1. Tank model, capacity

[SP-type (no frame), A-type (with frame), SA-type (concentrated sulfuric acid storage),

SL-type (slim tank), N-type (open), etc.]

[AT-type (no residual liquid), ATN-type (no residual liquid open type), etc.]

type L

3. Seismic resistance factor G

0.6G is standard. Leave blank if there is no preference.

4. Tank specification

Reinforced frame	<input type="checkbox"/> No preference	Required→	<input type="checkbox"/> SS	<input type="checkbox"/> SUS	<input type="checkbox"/> Hot dip galvanizing(up to 20,000L)	<input type="checkbox"/> Galvanized steel
Ladder	<input type="checkbox"/> Not required	Required→	<input type="checkbox"/> SS	<input type="checkbox"/> SUS	<input type="checkbox"/> Hot dip galvanizing	<input type="checkbox"/> Protection guard
Handrail	<input type="checkbox"/> Not required	Required→	<input type="checkbox"/> SS	<input type="checkbox"/> SUS	<input type="checkbox"/> Hot dip galvanizing	
Agitator stand or base	<input type="checkbox"/> Not required	Required→	<input type="checkbox"/> Portal	<input type="checkbox"/> Vertical	<input type="checkbox"/> SS	<input type="checkbox"/> SUS
			<input type="checkbox"/> Hot dip galvanizing			

* Required nozzle drawing (fill in the nozzle position, size and mounting part below)

Example: 100A air vent, 50A liquid input port, 50A liquid outlet

5. Company name

6. Contact name

7. Quotation destination

(Facsimile number or email address)

8. Requested response date for quotation

9. Delivery location

(prefecture name, user name, etc.)

10. Deadline for delivery/other

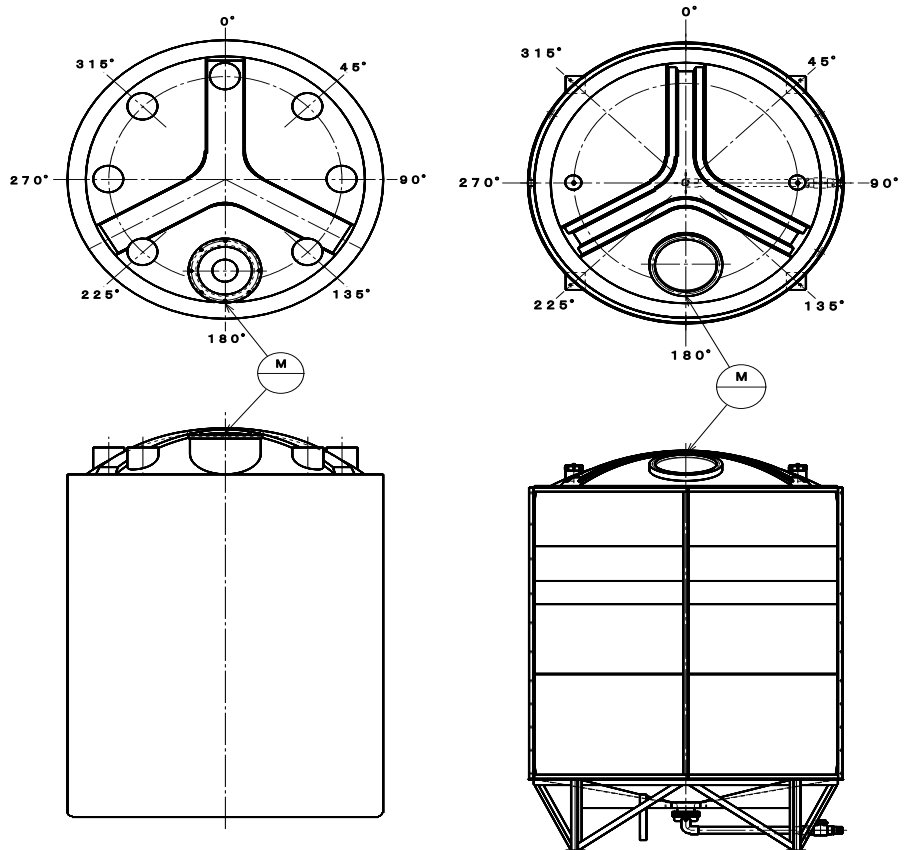

AT-type (No residual liquid tank)

Manufacturer branch office	email
Tokyo Head Office	tank@dailite.co.jp
Osaka Branch	osaka@dailite.co.jp
Nagoya Sales Office	nagoya@dailite.co.jp
Sendai Sales Office	sendai@dailite.co.jp
Fukuoka Sales Office	fukuoka@dailite.co.jp

12-Apr-24